

# UT6200 / UT6200RL UT8200 / UT8200RL

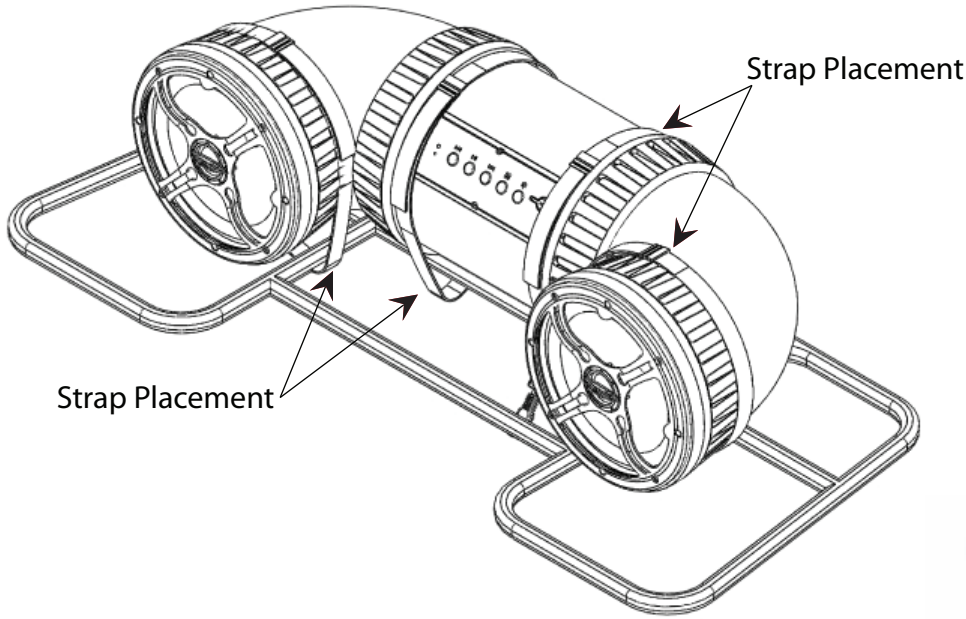

## Installation Instructions



With mounting base



Path of strap

Place the Bazooka UTube on the ATV rack. If being mounted to a flat surface use the mounting bases. Remove bases from strap if being used on a bar rack or if you do not want to mount strap bases. Wrap strap around the UTube then adjust strap to correct length. Fasten the buckles as illustrated. The strap should loop through the buckle and be tightened securely by holding the strap in place with one hand and pulling the loose end away from the buckle, but against the cabinet. Then secure the hook & loop ends to the strap. Repeat with the 3 remaining straps.

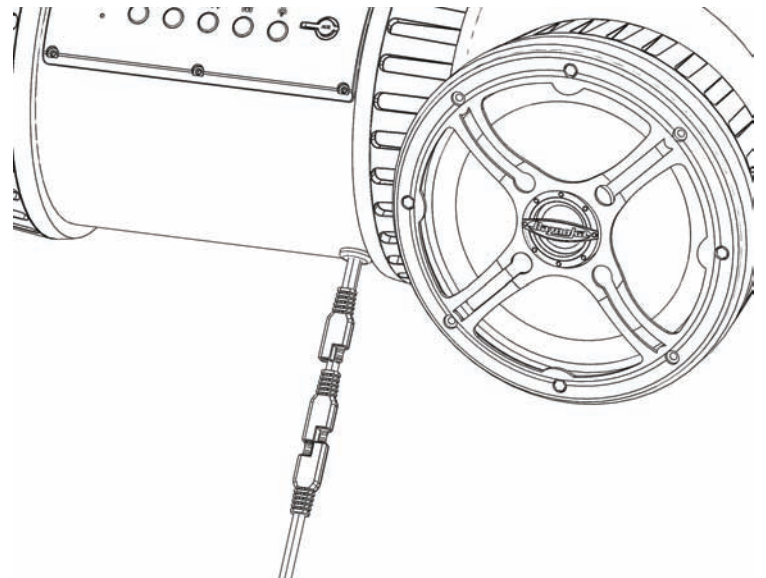
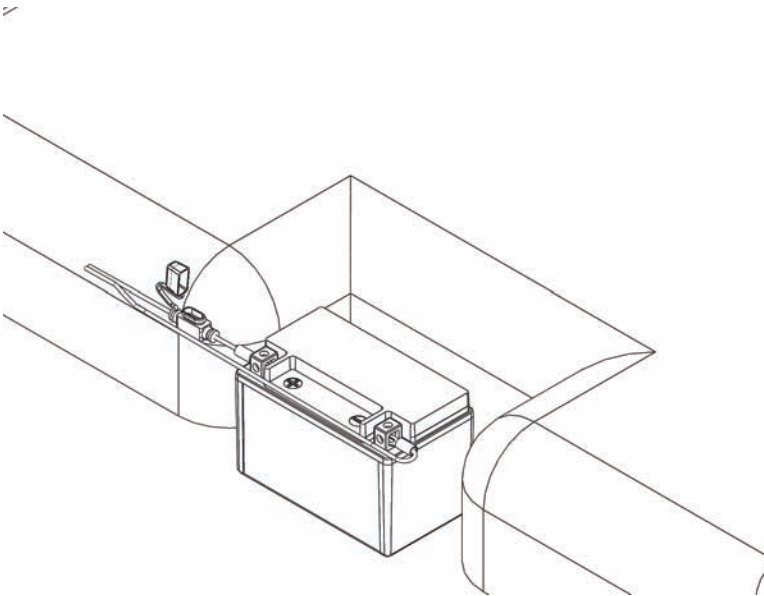

Remove fuse from 6 ft power cable. Attach the red wire to the positive battery terminal. Attach the black wire to the negative battery terminal. Run power cable to the location of the UTube. making sure power wire does not hinder the safe operation of the vehicle. Plug the red power cable end into the UTube's red input power plug. The black 12vdc accessory plug can be used to power any 12vdc accessory up to 15 amps. Use the black accessory pigtail to wire your accessories.

UT6200 / UT6200RL  
UT8200 / UT8200RL



Installation Instructions

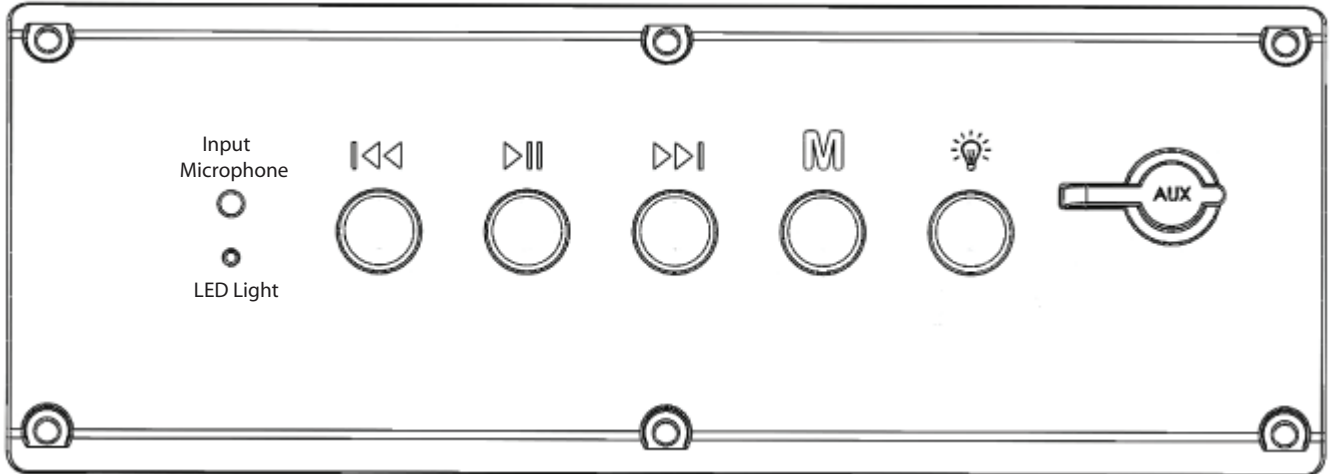

**Button 1** ⏮ Press to go back one track, Press and hold to decrease volume.

**Button 2** ⏸ Press to play/pause, Press to answer/hang up phone, Double press for last number radial or open Siri on Iphone, Press and hold to unpair bluetooth device.

**Button 3** ⏭ Press to go forward one track, Press and hold to increase volume.

**Button 4** M Press to power on, press while power is on to switch input between aux. and bluetooth inputs, Press and hold to power off.

**Button 5** 💡 Auxiliary 12vdc output on/off switch.

**AUX Socket** Used for a 1/8" audio cable

### LED light status indicator:

LED Light	Description
Blinking:	Bluetooth module is pairing
Solid blue:	Bluetooth module is paired
Blue/Red:	Bluetooth module is in AUX input mode

### Bluetooth module audio indicators:

Audio Response	Description
Power on:	Module is turned on
Power off:	Module is turned off
Beep:	After LED light stops blinking means module is paired
Beep:	When play/pause button is pressed and held means module is unpaired from Bluetooth device.
Double Beep:	When forward button is pressed and held means module has reached maximum volume.

UT6200RL  
UT8200RL



Installation Instructions



## RF functions and the RF remote are only available the UT6200RL and UT8200RL models

### MUSIC FUNCTIONS

Press: Previous Song  
Press & Hold: Volume Down

Press: Play/Pause (Phone Answer/Hang Up)  
Double Press: Last number redial or Enter Siri on iPhone  
Press & Hold: Unpair Bluetooth device and enter Pairing Mode for new Bluetooth device.

Press: Mode Select (AUX/Bluetooth)  
Press & Hold: Power On/Off \*

### LED FUNCTIONS

LEDs On/Off

Speed Up

Color Forward

Color Back

### SWITCH FUNCTIONS

Switch 1 On/Off

Switch aux. 12vdc (15 amp) output.

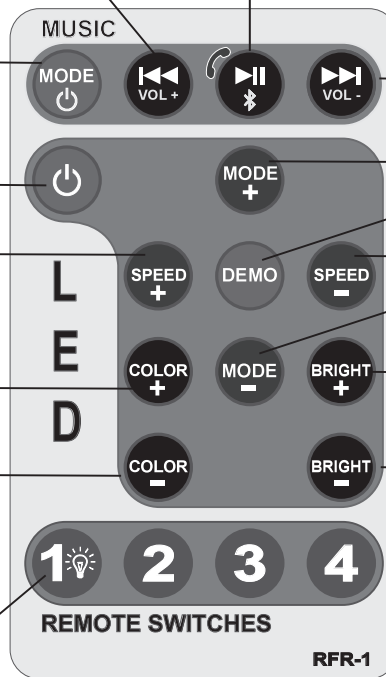

Press: Next Song  
Press & Hold: Volume Up

Mode Forward

DEMO Mode

Speed Down

Mode Back

Brightness Up

Brightness Down

**Remote switch buttons 2-4 are not used with the UT6200RL or the UT8200RL models**

Note: \* When pressing for Power Off, be sure to hold until Power Off is indicated (audible). Failure to do so may toggle the Bluetooth Receiver into AUX/BT Mode and it will remain in this mode on subsequent Power on/off. If this occurs, press button again to select BT/AUX mode. Receiver should automatically pair with the last device it was paired with. To pair with a new device press and hold the Play/Pause button.



Southern Audio Services, Inc., warrants all products to be free from defects in material and workmanship for a period of one (1) year from the date of purchase. In the event the product is not as warranted, SAS's sole obligation shall be to repair or replace the defective product at SAS's option: SAS limits its obligation under any implied warranties under state laws to a period not to exceed the limited warranty period. SAS and its authorized dealers specifically disclaim liability for any incidental or consequential damages. Some states do not allow limitations on how long an implied warranty lasts, and some states do not allow the exclusion or limitation of incidental or consequential damages, so the above limitation or exclusions may not apply to you. This warranty gives you specific legal rights, and you may have other rights, which vary from state to state.

**What is covered:** This warranty covers all defects in materials or workmanship (parts and labor) in the product.

**What is not covered:** This warranty does not cover the following:

1. Damages occurring during shipment of the product to SAS for repair (Claims must be presented to the carrier).
2. Damages caused by accident, abuse, negligence, misuse or improper Operation or installation.
3. Damages caused by an act of God, including without limitation, fire, flood Storm or other acts of nature.
4. Any product, which has a serial number, defaced, altered, modified, or removed.
5. Any product that has been altered or modified without SAS's consent.

**How to obtain warranty services:**

1. You are responsible for delivery of the product to SAS or contact SAS at 1-800-THE TUBE for a Return Authorization number. The Return Authorization number must be clearly written on the outside of the box. Freight must be prepaid to SAS. Warranty replacement parts will be returned freight prepaid. The entire product may be returned for warranty service, but return will be freight collect.
2. You must provide proof of the date of purchase of the product. If proof of purchase is not provided, original date of manufacture will be used to determine warranty period.
3. You must package the product securely to avoid damage during shipment.
4. After acquiring a Return Authorization number, ship to the address below. Please complete this section and retain for your records.

Southern Audio Services  
 14763 Florida Blvd.  
 Baton Rouge La. 70819

Model(s) purchased \_\_\_\_\_

Serial number(s) \_\_\_\_\_

Date Purchased \_\_\_\_\_

Place of Purchase \_\_\_\_\_